

Supersedes 200765C

SEAGULL[®] IV

Drinking Water Systems

Includes NEW Antimicrobial Cartridge & Housing Gaskets

- ◆ Purifies* water instantly
- ◆ Environmentally-friendly: No chemicals or electricity required
- ◆ Removes tank taste and more
- ◆ Bottled or better water quality



drinking



cooking



ice-cubes

NO MORE TANK TASTE!

Seagull IV X-1F Purifier



General Ecology, Inc.
www.generalecology.com

*Independently certified to meet EPA Guide Standard Protocol for Microbiological Purifiers against bacteria, cysts and viruses

Here's how "Structured Matrix™" technology purifies your water without using chemicals

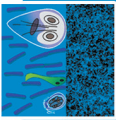
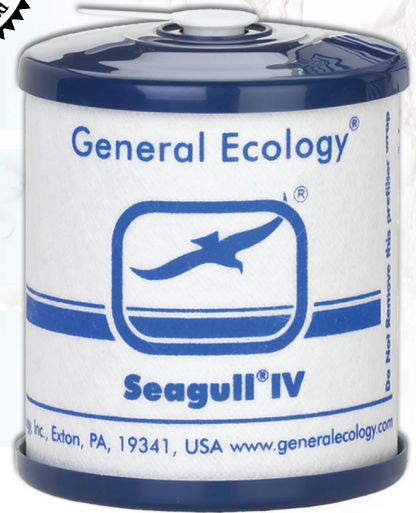

ULTRAFINE MICROTRAINING

physically removes disease bacteria, pathogenic cysts like Giardia, Cryptosporidia, and other specific parasites and debris down to 0.4 microns. Removing pathogens also removes disease-causing toxins in the organisms.

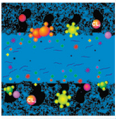

BROAD SPECTRUM MOLECULAR CAPTURE

traps and captures specific organic and other chemicals such as pesticides, herbicides and solvents, as well as chlorine and other trace contaminants that can be toxic and/or carcinogenic, along with many foul tastes, odors, and color.

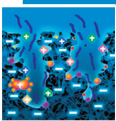

ELECTROSTATIC REMOVAL

uses specially charged surfaces, essentially as chemical magnets, to remove minute particles, molecules and colloids suspended in the water.

These purification mechanisms all work together to naturally and ecologically remove contaminants from your drinking water. With "Structured Matrix" technology you don't have to drink chlorine or other pesticides.

Beauty and Durability

Seagull IV X-1F includes a pure water FP faucet and stainless steel ports for exceptional beauty as well as durability.

Easily Installed!

Top mounting pure water faucet and "Quick and Easy™" pressure-proof installation lines eliminate the need to work in the cramped recesses under your sink.



Seagull™ IV X-1F
p/n 732000

NO MORE TANK TASTE!

Cartridge Wrap

All units include the RS-1SG purification cartridge with a pre-filter wrap for added value.

Low Cost, Foolproof Operation!

Operates solely from your pressurized water system and requires no chemicals, post treatment storage tanks, waste-water lines or electricity.

NEW Gaskets

Seagull IV X-1 and X-2 systems are now supplied with new antimicrobial Cartridge and Housing Gaskets. Although earlier gaskets continue to function reliably and effectively, these new gaskets are more environmentally friendly, and the Cartridge Gasket offers increased convenience, eliminating the need for adhesives.



Antimicrobial Self Threading Cartridge Gasket (pn 710553)



Antimicrobial Housing Gasket (pn 710550)

Dimensions: Seagull™ IV X-1F

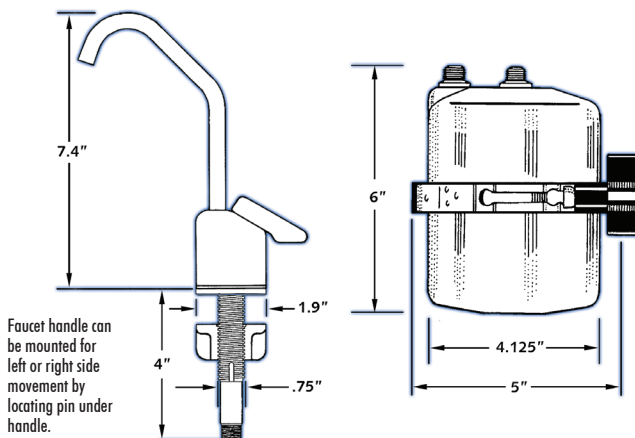

Technical Specifications

Operating Temperature33° F – 100° F (0.5° C – 38° C)**
Flow Rate1.0 Gallon/min (3.8 Liters/min)
Cartridge Capacity*, Avg.1,000 Gallons (3800 Liters)
Operating Pressure25 psi - 125 psi
Particle Retention0.4 - micron
Seagull™ IV X-1F Purifier, chrome faucetp/n 732000
RS-1SG Replacement Cartridgep/n 788000

*Performance may vary depending on influent water quality. **Intended for COLD WATER USE. Does not desalinate. • Patented in the U.S.A. • International Patents Pending

AS9100, ISO 9001 and FAA Quality Certified Original Equipment and PMA Manufacturer

800-441-8166 (ET) USA

www.generalecology.com • info@generalecology.com

General Ecology, Inc.

the pure science of safe water™



151 Sheree Blvd., Exton, Pennsylvania 19341-1292 USA

Distributed by: